

Smart Cane for Visually Impaired People

J.Ramprabu, Gowthaman.T

*Department of EEE, Kumaraguru college technology,
Coimbatore,Tamilnadu-641301, India.*

Abstract: This paper enlightens the visually impaired people to acclimatize for the environment which they find more difficult for their navigation system. The lack of visual observation is a loss of freedom to those people. This means they are dependent on other human being for navigation in both indoor and outdoor areas. In the older days the cane navigation system used to help the visually impaired people to avoid the obstacles and give the direction left, right, forward, backward, but it is not much more help for them to identify, what kind of obstacle and to conquer it. Another problem is this system is helpful only in indoors and it will not work in outdoor environments. Then group of sensor and actuators in the system causes the cane device more weight which is difficult to use in the undulation environments and it leads the device size larger which is more difficult to visually impaired people for their navigation. In addition to that the cost of the device is high. In order to overcome the subsequent complexes of visually impaired people. There is a considerable solution is proposed to help visually impaired people in the visualization of environment in easy way. The main objective of this project is used to help visually impaired people to navigate safely and quickly among the obstacles. The proposed system is smart cane which is used for the smart navigation for visually impaired people in indoor and outdoor environment respectively. The smart cane consist of camera which is used identify the obstacles. The captured image is send to the pc which is used to analysis the obstacles. The controller is used to intimate the type of obstacles and their distance through voice.

Keywords- visually imparied, undulation environments, cane

1.INTRODUCTION:

Human being performance modeling has several latent benefits for the study of human machine relations and system drawing. Much awareness has been developed, from act point such as models of reaction time, movement time, and detection odds to process underlying individual performance. The sightlessness is the key fact which is formed due to physiological or neurological issues which was leads to be short of visual perception. The World Health Organization (WHO) projected worldwide, the number of people of all ages visually impaired is estimated to be 285 million, of whom 39 million are blind. People 50 years and older are 82% of all blind. The main causes of visual impairment are uncorrected refractive errors (43%) and cataract (33%) which is the first cause of blindness is cataract (51%). Visual impairment in 2010 is a major global health issue. The preventable causes are as high as 80% of the total global burden. This means around 45 million people depended on other humans for navigation, information dispensation and ecological analysis due to blindness. Now a day's the society depends upon the social independence, the visually impaired likes to earn independence. Mislead of vision does not affect

the educational opportunities, social events but also hinders simple day to day activities. They requires assistive device for navigation, for understanding signs and manuscript to be independent. The exigent dilemma for their mobility has been classified into indoor and outdoor navigation. This routing fear restricts the visually impaired right to access many structure, precludes their use of public transit and makes their combination into local communities difficult. Thus in order to conquer routing concerns of visually impaired, there is a signification need for a new assisted navigation system to help the blind community in the visualization of environment at easiness. Advances of technology and better awareness in human observation permit the design and enlargement of new influential and high-speed interface assisting human with disabilities. It is observably they also rely on walking canes to navigate in known and unknown environment. They are many canes of different colors, size and height. Problem related to mobility assistance are more challenging.

They involve spatial information of the immediate environment, orientation and obstacle avoidance. These simply planned canes are only capable of detecting below waistline obstacles and give simple guidance between distances. Many electronic travel aided cane for safe and independent mobility of the blind have been proposed but due to increase in load this leads to failure. Although these canes are capable of finding obstacles, receiving feedback is very low. The type of obstacles is not clear mentioned where there is difficulty overcoming the obstacle. Therefore visually impaired people still find to difficult navigate specially in unknown environments.

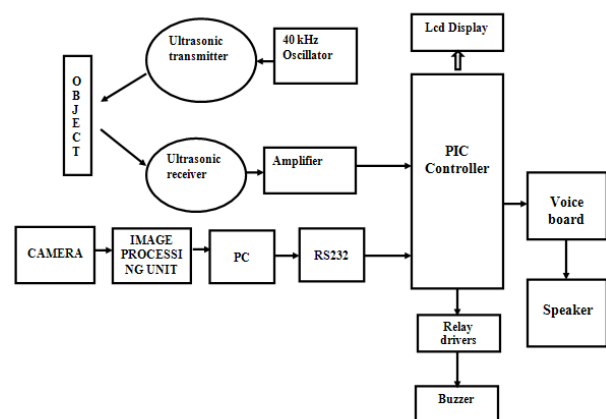

Fig.1 Block diagram

2. SYSTEM DESIGN:

The block consists of ultrasonic transmitter, Receiver, Amplifier frequency to voltage converter, PIC controller, Camera, Image Processing unit, PC, RS232 and Display, Voice board and speaker. In ultrasonic a frequency of 40 KHz is to be generated which done by the oscillator .The generated frequency is transmitted through the ultrasonic Transmitter sensor which it is subjected back when an obstacle is placed. The reflected back frequency is received in the ultrasonic receiver sensor. Thus with respect to the time the reflection of the noise to what distance is received .The received output is amplified, which is converted to voltage. This voltage output which is analog is given to the PIC Controller. Any obstacle is sensed, the voice information about is announced with the help of voice board and speaker which is controlled by the PIC Controller. Buzzer will get alarmed through Relay driver unit. LCD Display is used to display the information about the system which is connected with the PIC Controller. Camera is used to pick up the image of the object which is connected to the image processing unit. The image of the object will be scanned by the image processing Scanner in the image processing unit. Then the scanned image will be registered with the help of the system. We can registered many no of images of the object.RS232 is used for serial communication between the Image processing unit and the PIC controller unit. The Registered image information will be announced through Speaker with the help of voice board and the controller.

Ultrasonic Circuit Operation:

Ultrasonic sensor which transmits and receives the ultrasonic signal. The transmitter of ultrasonic sensor transmits the signal on the object and reflects the signal to the receiver of the sensor. The signal transmitted on the object and received by the object in the frequency of 40 kHz. The frequency of 40 kHz is generated by the PIC controller. The crystal oscillator is connected to the PIC controller which generates the frequency. The AND GATE is connected to the PIC controller which acts as switch. When the two input are high then the output of the AND gate will be high. If the two inputs are different ie (high and low) then the output will be low. Two inputs are connected to the PIC controller. If the both are high then output is high and it is applied to the transistor (CL100) which is connected to the AND gate. There are two transistor is used to improve the current source. The input for transistor is in micro amps from the AND gate and is improved to milliamps by the two section of transistor. The base of the transistor1 is connected to the AND gate and emitter of transistor 2 is grounded with transistor 1. Then supply voltage is applied to collector of both transistors which is connected together. The output of transistor 1 is applied to the base of transistor2 and the output is applied to the ultrasonic transmitter. It transmits the ultrasonic signal which is received by the receiver. The time taken for transmitting and receiving the signal, PIC controller will make delay and AND gate will be low. After receiving the signal by the receiver and performance takes places. The

frequency of 40 kHz will be send to the transmitter through the circuit. The receiver receives the signal with distortion. To avoid distortion, capacitor is used for filter and the signal is amplified by the two stage of inverting amplifier. It will improve the signal after the process of amplification with gain. The second and sixth pin dual op-amp is the inverting terminal. Third and fifth pin of dual op-amp is non-inverting terminal. Pin 1 and 7 is the output for both stage of inverting amplifier. The output of the second stage inverting amplifier provides the analog signal which is applied to the driver.

RS232 Serial Communication:

In RS-232, user data is sent as a time-series of bits. Both synchronous and asynchronous transmissions are supported by the standard. In addition to the data circuits, the standard defines a number of control circuits used to manage the connection between the DTE and DCE. Each data or control circuit only operates in one direction that is, signaling from a DTE to the attached DCE or the reverse. Since transmit data and receive data are separate circuits, the interface can operate in a full duplex manner, supporting concurrent data flow in both directions. The standard does not define character framing within the data stream, or character encoding. The RS-232 standard defines the voltage levels that correspond to logical one and logical zero levels. Valid signals are plus or minus 3 to 15 volts. The range near zero volts is not a valid RS-232 level; logic one is defined as a negative voltage, the signal condition is called marking, and has the functional significance of OFF. Logic zero is positive, the signal condition is spacing, and has the function ON. The standard specifies a maximum open-circuit voltage of 25 volts; signal levels of ± 5 V, ± 10 V, ± 12 V, and ± 15 V are all commonly seen depending on the power supplies available within a device. RS-232 drivers and receivers must be able to withstand indefinite short circuit to ground or to any voltage level up to ± 25 volts. The slew rate, or how fast the signal changes between levels, is also controlled. Because the voltage levels are higher than logic levels typically used by integrated circuits, special intervening driver circuits are required to translate logic levels. These also protect the device's internal circuitry from short circuits or transients that may appear on the RS-232 interface, and provide sufficient current to comply with the slew rate requirements for data transmission.

Signals:

Commonly-used signals are:

Transmitted Data (TxD)

Data sent from DTE to DCE.

Received Data (RxD)

Data sent from DCE to DTE.

Request To Send (RTS)

Asserted (set to logic 0, positive voltage) by DTE to prepare DCE to receive data. This may require action on the part of the DCE, e.g. transmitting a carrier or reversing the direction of a half-duplex channel.

PIC Microcontroller:

PIC device is high performance RISC CPU. There are 35 single word instructions. All single cycle instructions except for program branches which are two cycle. Operating speed: DC - 20 MHz clock input DC - 200 ns instruction cycle. The memory organization is up to 8K x 14 words of FLASH Program Memory, 368 x 8 bytes of Data Memory (RAM), 256 x 8 bytes of EEPROM Data Memory. Pin out compatible to the PIC16C73B/74B/76/77. The interrupt capability (up to 14 sources) eight level deep hardware stacks. The addressing modes are direct, indirect, and relative addressing modes.

LCD:

The most commonly used Character based LCDs are based on Hitachi's HD44780 controller or other which are compatible with HD44580. In this project document, we will discuss about character based LCDs, their interfacing with various microcontrollers, various interfaces (8-bit/4-bit), Display data RAM (DDRAM) stores display data represented in 8-bit character codes. Its extended capacity is 80 X 8 bits, or 80 characters. The area in display data RAM (DDRAM) that is not used for display can be used as general data RAM. So whatever you send on the DDRAM is actually displayed on the LCD. For LCDs like 1x16, only 16 characters are visible, so whatever you write after 16 chars is written in DDRAM but is not visible to the use.

Image processing:

The Hough transform algorithm uses an array, called an accumulator, to detect the existence of a line. The dimension of the accumulator is equal to the number of unknown parameters of the Hough transform problem. For each pixel and its neighborhood, the Hough transform algorithm determines if there is enough evidence of an edge at that pixel. If so, it will calculate the parameters of that line, and then look for the accumulator's bin that the parameters fall into, and increase the value of that bin. By finding the bins with the highest values, typically by looking for local maxima in the accumulator space, the most likely lines can be extracted, and their (approximate) geometric definitions read off. The simplest way of finding these peaks is by applying some form of threshold, but different techniques may yield better results in different circumstances - determining which lines are found as well as how many. Since the lines returned do not contain any length information, it is often next necessary to find which parts of the image match up with which lines. Moreover, due to imperfection errors in the edge detection step, there will usually be errors in the accumulator space, which may make it non-trivial to find the appropriate peaks, and thus the appropriate lines.

The result of the Hough transform is stored in a matrix that often is called an accumulator. One dimension of this matrix are the angles θ and the other dimension are the distances r , and each element has a value telling how many points/pixels are positioned on the line with parameters (r,θ) . So the element with the highest value tells what line that is most represented in the input image

3. SYSTEM OPERATION:

The proposed system consists of camera unit which is used to capture the obstacle images and send to the pc. The image processing unit is used to analysis the images with help of the software The image of the object will be scanned by the image processing Scanner in the image processing unit. Then the scanned image will be registered with the help of the system. We can registered many no of images of the object.RS232 is used for serial communication between the Image processing unit and the PIC controller unit. The Registered image information will be announced through Speaker with the help of voice board and the controller. The ultrasonic sensor used to determine the distance of the objects.

4. SOFTWARE DESCRIPTION:

Software is developed in embedded C language and mat lab Algorithm/lab view for online monitoring and guidance for visually impaired people. Algorithm for smart cane is as follows.

1. Start
2. Initialize CAMERA.
3. Initialize LCD.
4. Initialize RS232
5. Initialize ultrasonic sensor
6. Get the images
7. Analysis the images through algorithm
8. Register the images
10. Get the images
11. Compare the images
12. Get the distance from sensor unit
13. If distance = near initialize the buzzer
14. Initialize the voice unit
15. Announce the objet type, distance and shape.

5. RESULT AND CONCLUSIONS:

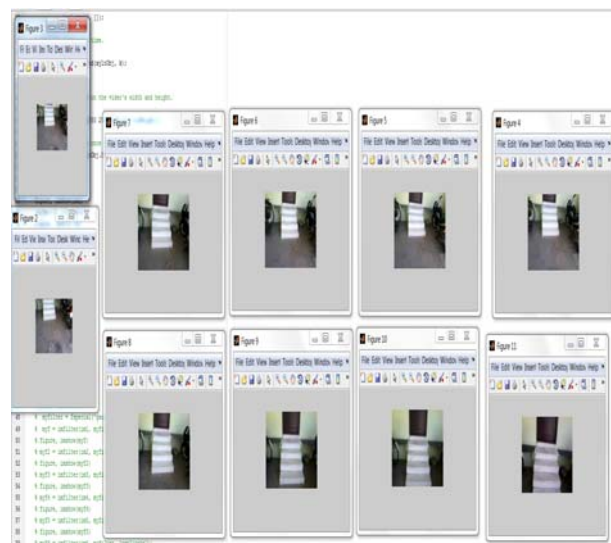

Fig.2 input framed images

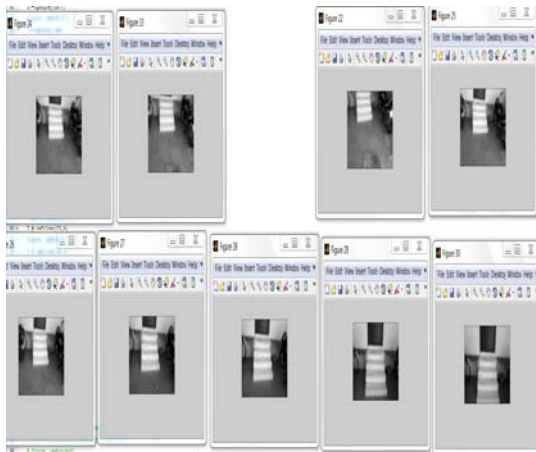

Fig.3.filtered images

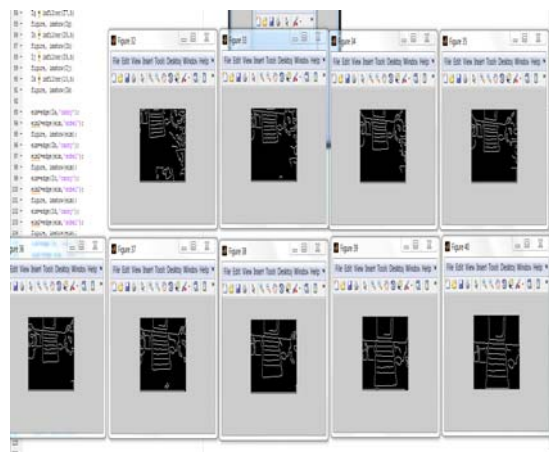
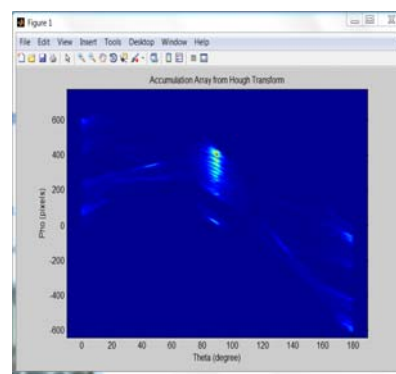

Fig.4.edge detected image



Original image



Accumulation array

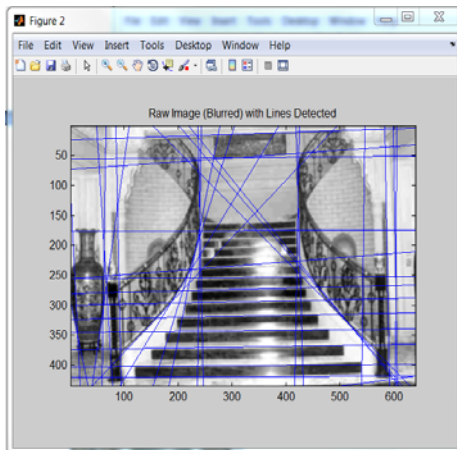

Rawimage

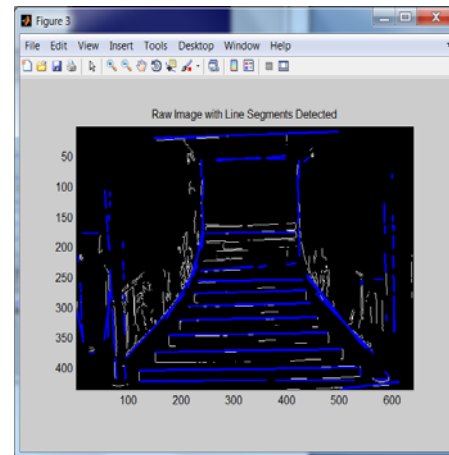

Raw image with line Segments detected

The maximum size of the line detected is 3feet

Fig.5.stand still images

Thus the project help visually impaired people to overcome all difficulties over various environments. The main idea behind this project is to help the visually impaired people for safe and quick navigation over the obstacle indoor and

outdoor environment. The special classifier is used for the analysis of object in different illumination conditions and codec is used to generate the voice signal for purpose of navigation.

REFERENCE:

- [1]. Assistive Technology for Vision- impairments: An Agenda for the ICTD Community: WWW 2011, March 28–April 1, 2011, Hyderabad, India. ACM 978-1-4503-0632-4/11/03.
- [2]. A pervasive assistive environment for visually impaired people using wireless sensor network infrastructure: Journal of Network and Computer Applications 34 (2011) 194–206:2011 ELSEVIER
- [3]. Researchers, Vendors Use AI to Enable the Disabled Published by the IEEE Computer Society:2011 IEEE
- [4]. Saaid, M.F.; Ismail, I.; Noor, M.Z.H.; , "Radio Frequency Identification Walking Stick (RFIWS): A device for the blind," Signal Processing & Its Applications, 2009. CSPA 2009. 5th International Colloquium on , vol., no., pp.250-253, 6-8 March 2009
- [5]. Tsai, L.W., Hsieh, J.W., Chuang, C.H., Fan, K.C.: Lane detection using directional random walks. In: IEEE Intelligent Vehicles Symposium 2008.